

PRESSURE RELIEF VALVES

Angle & Straight-Thru Types

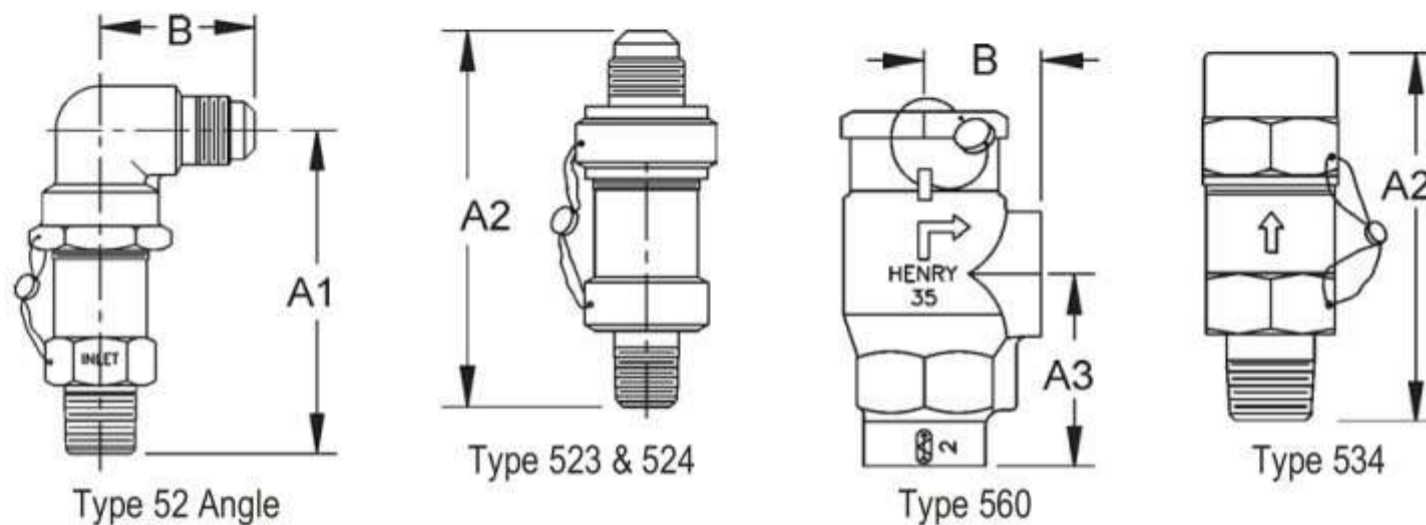

Straight-Through Relief Valves					
Catalog Number	Size Conn.		Length, In "A2"	Orifice Diam.	Weight lbs.
	Inlet	Outlet			
5230	1/4" M.P.T.	3/8" FL.	3.16	0.250	0.38
5231	3/8" M.P.T.	3/8" FL.	3.16	0.250	0.39
5232	1/2" M.P.T.	5/8" FL.	4.00	0.437	0.85
5232B	1/2" M.P.T.	1/2" F.P.T.	4.02	0.437	0.97
5240N1/2	1/2" M.P.T.	3/4" F.P.T.	3.74	0.312	0.95
5242N3/4	3/4" M.P.T.	3/4" F.P.T.	3.74	0.312	1.03
*5340N1/2	1/2" M.P.T.	3/4" F.P.T.	3.70	0.312	0.95
*5342N3/4	3/4" M.P.T.	3/4" F.P.T.	3.70	0.312	1.03
5244-3/4	3/4" M.P.T.	1" F.P.T.	4.16	0.500	1.46
5244-1	1" M.P.T.	1" F.P.T.	4.16	0.500	1.46
*5344-3/4	3/4" M.P.T.	1" F.P.T.	4.19	0.500	1.46
*5344-1	1" M.P.T.	1" F.P.T.	4.19	0.500	1.46
5246N1	1" M.P.T.	1-1/4" F.P.T.	6.30	0.531	2.50
5246N1-1/4	1-1/4" M.P.T.	1-1/4" F.P.T.	6.30	0.531	2.60
*5345N	1" M.P.T.	1-1/4" F.P.T.	6.30	0.531	2.50
*5346N1-1/4	1-1/4" M.P.T.	1-1/4" F.P.T.	6.30	0.531	2.60
5233A	3/8" M.P.T.	7/8" FL.	4.56	0.250	1.05
5234A	3/8" M.P.T.	3/4" F.P.T.	4.20	0.250	1.05
5235A	1/2" M.P.T.	3/4" F.P.T.	4.40	0.250	1.12

Features:

- **Bodies:** 5600 Series, Ductile Iron; 5300 Series, Stainless Steel; 5200 Series, Brass
- **Seat** inserts, seat discs and main guides, piston stainless steel on 5600 series
- **Seat material:** Teflon® or Neoprene
- **Connections:** (NPTF) pipe threaded
- **Other component** metal parts are steel
- **Set and sealed** at the factory and furnished with nameplates stamped with catalog no., size, pressure setting, capacity and ASME-UV National Board symbol
- **Temperature rating:** -20°F (-28°C) to +160°F (+71°C)
- **Protective lacquer** finish on 5600 series
- ***Suitable for ammonia**, HFC's and CFC's, refrigerants and other industrial fluids non-corrosive to steel and Teflon as indicated
- **Each valve** has unique serialization for tagging requirements

* Suitable for Ammonia

Angle Relief Valves							
Catalog Number	Size Connection		Dimensions in Inches			Orifice Dia.	Weight lbs.
	Inlet	Outlet	A1	A3	B		
526E	3/8" M.P.T.	3/8" FL.	2.96	—	1.41	0.250	0.40
527E	1/2" M.P.T.	5/8" FL.	3.81	—	1.72	0.437	0.85
*5600	1/2" F.P.T.	3/4" F.P.T.	—	2.69	1.63	0.500	3.60
*5601	1/2" F.P.T.	1" F.P.T.	—	2.69	1.63	0.500	3.44
*5602	3/4" F.P.T.	1" F.P.T.	—	2.69	1.63	0.500	3.40
*5603	1" F.P.T.	1-1/4" F.P.T.	—	2.88	2.00	0.500	4.75
*5604	1-1/4" F.P.T.	1-1/2" F.P.T.	—	4.13	2.31	0.703	6.50

HENRY® VALVE Industrial & Commercial Refrigeration Products 800.96.HENRY

H23

PRESSURE RELIEF VALVES

Angle & Straight-Thru Types



Features:

Relief Valves in the types and sizes shown are constructed in accordance with the requirements of the ASME. These valves are also approved by many local refrigeration and air conditioning codes in the USA and Canada for relief of excess pressure. In addition, these valves are stamped with ASME- UV symbol and NB to indicate National Board certification of capacities between 150 P.S.I. and 450 P.S.I.

Whenever conditions permit, it is advisable to have the relief valve pressure setting (which must not exceed the design working pressure of the vessel) at least 25 percent higher than the normal maximum operating pressure for the refrigerant used.



* Suitable for Ammonia

National Board Certified Relief Valve Capacity Ratings (pounds of air per min.)						
Catalog Number	Pressure Settings—PSIG					
	150	235	300	350	400	450
5230	5.0	7.6	9.6	11.2	12.7	14.3
5231	5.0	7.6	9.6	11.2	12.7	14.3
526E	5.0	7.6	9.6	11.2	12.7	14.3
5232	12.6	19.1	24.2	28.0	31.9	35.7
5232B	12.6	19.1	24.2	28.0	31.9	35.7
527E	12.6	19.1	24.2	28.0	31.9	35.7
5240N1/2	13.1	19.9	25.1	29.2	33.2	37.2
5242N3/4	13.1	19.9	25.1	29.2	33.2	37.2
* 5340N1/2	13.1	19.9	25.1	29.2	33.2	37.2
* 5342N3/4	13.1	19.9	25.1	29.2	33.2	37.2
5244-3/4	33.2	50.5	63.8	73.9	84.1	94.3
5244-1	33.2	50.5	63.8	73.9	84.1	94.3
* 5344-3/4	33.2	50.5	63.8	73.9	84.1	94.3
* 5344-1	33.2	50.5	63.8	73.9	84.1	94.3
5246N1	44.6	67.8	85.2	99.1	112.8	126.4
5246N1-1/4	44.6	67.8	85.2	99.1	112.8	126.4
* 5345N	44.6	67.8	85.2	99.1	112.8	126.4
* 5346N1-1/4	44.6	67.8	85.2	99.1	112.8	126.4

Catalog Number	Pressure Settings—PSIG		
	150	250	300
5600	30.9	49.9	59.4
5601	35.8	57.7	68.7
5602	35.8	57.7	68.7
5603	37.5	60.4	71.9
5604	72.0	116.1	138.1

HIGH PRESSURE RELIEF VALVES UP TO 675 PSIG						
Catalog Number	Pressure Settings—PSIG					
	450	500	550	600	650	675
5233A	N/A	31.2	34.2	37.2	40.3	41.8
5234A	N/A	31.2	34.2	37.2	40.3	41.8
5235A	N/A	31.2	34.2	37.2	40.3	41.8

Capacity in CFM: To convert pounds of air per minute to standard cubic feet per minute, multiply by 13.3.

HENRY® VALVE Industrial & Commercial Refrigeration Products 800.96.HENRY

H24