Solenoid Valves

2-Way Solenoid Valves

Basic Terms and Technical Information

Operating principles

Directly actuated: The magnetic field of the solenoid coil forces a movement of the plunger and thus causes the opening of the valve seat.

Servo actuated: The magnetic field of the solenoid coil is only utilized for the opening of the pilot valve seat. The necessary energy to actuate the piston or diaphragm of the main valve seat is provided by the refrigerant flow and results in a certain pressure drop.

Minimum pressure drop

Directly actuated solenoid valves do not require a minimum pressure drop for proper operation. Servo operated solenoid valves require a minimum pressure drop of approximately 0.05 bar to remain fully open. In case of insufficient refrigerant flow this value will not be reached and the solenoid valve may close unintentionally. These closures may lead to malfunctions and oscillations in the refrigeration circuit. Improper sizing of solenoid valves (i.e. use of excessively large solenoid valves) is the main cause of this effect. This is particularly important in capacity controlled refrigeration circuits.

Therefore the decisive factor for proper solenoid valve sizing is the respective capacity of the valve and not its connection size.

Formula for calculating the actual pressure drop of a solenoid valve:

$$\Delta_{p1} = \Delta_{p2} \times (Q_{n1}/Q_{n2})^2$$

- Δ_{p1} : Actual pressure drop
- Δ_{p2} : Nominal pressure drop at Q_{n1}
- Q_{n1} : Calculated nominal capacity
- Q_{n2} : Nominal capacity of selected valve

Maximum Operating Pressure Differential (MOPD)

MOPD is the maximum pressure differential between inlet and outlet of the solenoid valve which permits proper opening of the valve. When used with ALCO AC solenoid coils all ALCO solenoid valves employ 25 bar MOPD.

Operation in conjunction with DC solenoid coils lead to reduced MOPD values depending on valve type and size.

The **DS2 Chopper Plugs** allow the use of 24VAC coils with 24VDC by converting the DC in an AC voltage. Please contact ALCO application engineering for additional details.

Selection Guide for Solenoid Valves

Selection Criteria	Series						
	110 RB	200 RB	240 RA		540 RA		M36
			8/9/12/16T9	16T11/20	8/9/12/16	20	
2-Way	+	+	+	+	+	+	
3-Way							+
Normally Closed (NC)	+	+	+	+			
Normally Open (NO)					+	+	
Min. Pressure Differential (bar)	0.00	0.05	0.05	0.05	0.05	0.05	
MWP (bar)	31	31	31	31	31	28	35
Media Temp. Range (°C)	-40 / +120	-40 / +120	-40 / +120	-40 / +120	-40 / +120	-40 / +120	-40 / +120
Coil Type	ASC	ASC	ASC	ASC	ASC	ASC	ASC
Catalogue Page	94	94	94	94	95	95	98

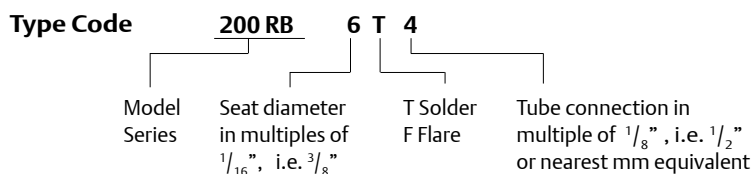

Coils ASC

Standards

- ALCO ASC Coils and cable assemblies conform to Low Voltage Directive



ASC

Type	Part No.	Voltage	Power Input	Electr. Connection	Protection
ASC 230V / 50Hz	801 064	AC	8 W	without plug, see cable assemblies	IP65 with plug / cable assembly
ASC 120V / 50Hz	801 063				
ASC 24V / 50Hz	801 062				
ASC 12V	801 054	DC	15 W		
ASC 120V	801 050				
ASC 230V	801 056				

Note: Coils are delivered with mounting clip.
Please order cable assemblies separately.



ASC-N15

Cable Assemblies for ASC Coils

Type	Part No.	Temperature Range	Cable length	Wire diameter	Connector Type
ASC-N15	804 570	-50 .. +80°C	1,5m	3 x 0,75 mm ²	loose wires
ASC-N30	804 571		3,0m		
ASC-N60	804 572		6,0m		

Cable Assembly with 24V DC Chopper Plug

- Enables standard 24V AC Coil to be used for DC applications
- Low power assumption (3W only)
- No MOPD degradation



DS2-N15

Type	Part No.	Temperature Range	Cable length	Wire diameter	Connector Type
DS2-N15	804 620	-25 .. +80°C	1,5 m	2 x 0,75 mm ²	loose wires

Other Accessories for Solenoid Valves

Type	Part No.	Description
X 11981 - 1	027 451	Service tool for 110RB, 240RA, 540RA, 3031
X 13740 -1	027 600	Clip for coil
PG9 Plug	801 012	Plug according to DIN 43650 with cable gland PG 9
PG11 Plug	801 013	Plug according to DIN 43650 with cable gland PG 11

2-Way Solenoid Valves Series 110, 200, 240

Normally Closed

Features

- Compact size
- Snap-on clip for attaching solenoid coils
- No disassembly necessary for soldering

Standards

- 240 RA 16T11 and 20 are CE marked per PED

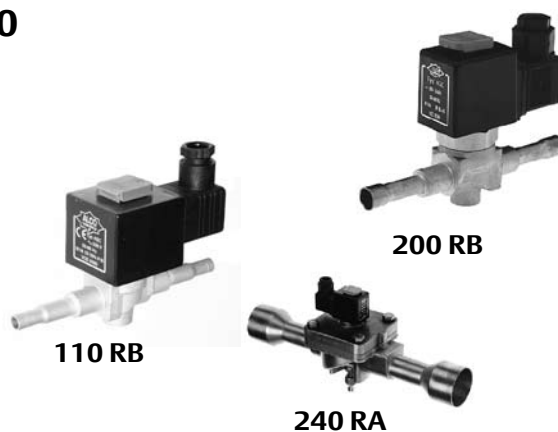

Capacity Data

Type	Nominal Capacity Q _n (kW)												kv-value m ³ /h	Δp min bar
	Liquid				Hot Gas				Suction Gas					
	R 134a	R 22	R 404A R 507	R 407C	R 134a	R 22	R 404A R 507	R 407C	R 134a	R 22	R 507	R 407C		
110 RB 2	3,5	3,8	2,5	3,6	1,6	2,0	1,7	2,1					0,2	0
200 RB 3	6,6	7,1	4,6	6,8	3,0	3,7	3,2	3,9					0,4	0,05
200 RB 4	15,5	16,8	10,9	16,1	7,1	8,8	7,5	9,2					0,9	0,05
200 RB 6	27,3	29,5	18,9	28,0	12,5	15,4	13,1	16,1					1,6	0,05
240 RA 8	36,3	39,3	25,2	37,3	16,7	20,5	17,4	21,4	4,2	5,6	4,6	5,2	2,3	0,05
240 RA 9	76,2	82,5	52,9	78,4	35,1	43,1	36,5	44,9	8,8	11,7	9,7	10,9	4,8	0,05
240 RA 12	85,7	92,8	59,5	88,1	39,4	48,4	41,1	50,5	9,9	13,1	10,9	12,3	5,4	0,05
240 RA 16	139,1	150,5	96,5	142,9	64,0	78,5	66,6	81,9	16,0	21,3	17,7	19,9	8,8	0,05
240 RA 20	202,6	219,3	140,7	208,3	93,2	114,4	97,1	119,3	33,0	31,0	25,7	29,0	12,8	0,05

Selection Guide

Type	Part No.	Connection Solder / ODF	
		mm	Inch
110 RB 2	T2	801 217	6
	T2	801 210	1/4
	T3	801 209	3/8
200 RB 3	T3	801 239	3/8
200 RB 4	T3	801 176	10
	T3	801 190	3/8
	T4	801 178	12
	T4	801 179	1/2
200 RB 6	T4	801 182	12
	T4	801 183	1/2
	T5	801 186	5/8
240 RA 8	T5	801 160	5/8
	T7	801 143	7/8
240 RA 9	T5	801 161	5/8
	T7	801 162	7/8
	T9	801 142	1-1/8
240 RA 12	T7	801 163	7/8
	T9	801 144	1-1/8
240 RA 16	T9	801 164	1-1/8
	T11	801 166	1-3/8
240 RA 20	T11-M	801 172	1-3/8
	T13-M	801 224	42
	T13-M	801 173	1-5/8
	T17-M	801 174	2-1/8

Nominal capacities at +38°C condensing temperature, +4°C evaporating temperature, 0.15 bar pressure drop between valve inlet and outlet in liquid applications (for hot gas applications 1 bar pressure drop and +18°C suction gas temperature); subcooling 1 K.

Correction tables for other operating conditions see page 96.

Special Versions:

- Manual stems available upon request for Series 240 RA 8 to 240 RA 16 (Type M).

Manual stems standard on Series 240 RA 20.

Options:

- Actuation coils available for various voltages, see page 93.

2-Way Solenoid Valves Series 540

Normally Open

Features

- Compact size
- Snap-on clip for attaching solenoid coils
- No disassembly necessary for soldering



540 RA

Capacity Data

Type	Nominal Capacity Q_n (kW)												kv-value m ³ /h	Δp min bar
	Liquid				Hot Gas				Suction Gas					
	R 134a	R 22	R 404A R 507	R 407C	R 134a	R 22	R 404A R 507	R 407C	R 134a	R 22	R 507	R 407C		
540 RA 8	36,3	39,3	25,2	37,3	16,7	20,5	17,4	21,4	4,2	5,6	4,6	5,2	2,3	0,05
540 RA 9	76,2	82,5	52,9	78,4	35,1	43,1	36,5	44,9	8,8	11,7	9,7	10,9	4,8	0,05
540 RA 12	85,7	92,8	59,5	88,1	39,4	48,4	41,1	50,5	9,9	13,1	10,9	12,3	5,4	0,05
540 RA 16	139,1	150,5	96,5	142,9	64,0	78,5	66,6	81,9	16,0	21,3	17,7	19,9	8,8	0,05
540 RA 20	202,6	219,3	140,7	208,3	93,2	114,4	97,1	119,3	23,3	31,0	25,7	29,0	12,8	0,05

Nominal capacities at +38°C condensing temperature, +4°C evaporating temperature, 0.15 bar pressure drop between valve inlet and outlet in liquid applications (for hot gas applications 1 bar pressure drop and +18 °C suction gas temperature); subcooling 1 K.

Correction tables for other operating conditions see page 96.

Selection Guide

Type	Part No.	Connection Solder /ODF	
		mm	Inch
540 RA 8	T5	046 265	5/8
540 RA 9	T5	046 266	5/8
	T7	046 268	22
540 RA 12	T7	046 269	22
540 RA 16	T9	046 270	1-1/8
540 RA 20	T11	047 953	35

Options:

- Actuation coils and cable assemblies available for various voltages, see page 93.

Accessories and spare parts for solenoid valves

Description	Type	Part No.
Service tool for 110 RB, 240 RA, 540 RA	X 11981 - 1	027 451
Gasket kits		
110RB	KS 30040-2	801 232
200RB	KS 30039-1	801 233
240RA8	KS 30061-1	801 234
240RA9/12	KS 30062-1	801 235
240RA16	KS 30065-1	801 236
240RA20	KS 30097-1	801 237

Repair Kits	Type	Part No.
110RB	KS 30040-1	801 206
200RB	KS 30039 / KS 30109	801 205
240RA8	KS 30061	801 262
240RA9	KS 30062	801 263
240RA12	KS 30063	801 264
240RA16	KS 30065	801 200
240RA20	KS 30097	801 216

Correction Tables for the Selection of Solenoid Valves

For use with 110 RB, 200 RB, 240 RA and 540 RA Series

Valve selection for operating conditions other than nominal:

The pressure drop can be calculated with the following formula:

$$Q_n = Q_o \times K_t \times K_{\Delta p}$$

$$\Delta P_o = \Delta P_n \times \frac{Q_o^2}{Q_n^2}$$

- Q_n : Nominal valve capacity
- K_t : Correction factor for evaporating and liquid temperature
- $K_{\Delta p}$: Correction factor for pressure drop at valve
- Q_o : Required cooling capacity

- $\Delta P_n = 0,15 \text{ bar}$
- ΔP_n : Pressure drop under nominal conditions

1. Suction Gas Application

Evaporating Temperature °C	Correction Factor K_t										
	Condensing Temperature °C										
	+60	+55	+50	+45	+40	+35	+30	+25	+20		
+10	1,03	0,97	0,92	0,88	0,84	0,80	0,76	0,74	0,71		
0	1,40	1,32	1,25	1,20	1,14	1,10	1,04	1,01	0,96		
-10	1,71	1,62	1,53	1,47	1,40	1,34	1,27	1,23	1,18		
-20	2,20	2,08	1,97	1,88	1,80	1,72	1,64	1,58	1,51		
-30	2,79	2,63	2,50	2,39	2,27	2,19	2,07	2,01	1,92		
-40	3,68	3,47	3,29	3,15	3,00	2,89	2,73	2,65	2,53		
Correction Factor $K_{\Delta p}$											
Δp (bar)	0,05	0,10	0,15	0,20	0,25	0,30	0,35	0,40	0,45	0,50	0,55
$K_{\Delta p}$	1,73	1,22	1,00	0,87	0,77	0,71	0,65	0,61	0,48	0,55	0,52

2. Liquid Application

Liquid Temperature entering Valve °C	Correction Factor K_t														
	R 134a					R 22									
	Evaporating Temperature °C														
	+10	0	-10	-20	-30	+10	0	-10	-20	-30	-40				
+60	1,33	1,40	1,48	1,56	1,67	1,26	1,30	1,38	1,38	1,44	1,50				
+55	1,23	1,29	1,36	1,43	1,52	1,19	1,22	1,29	1,29	1,34	1,39				
+50	1,15	1,20	1,26	1,32	1,39	1,12	1,15	1,21	1,22	1,26	1,30				
+45	1,08	1,12	1,17	1,22	1,29	1,06	1,08	1,15	1,15	1,18	1,23				
+40	1,01	1,05	1,10	1,14	1,20	1,01	1,03	1,09	1,09	1,12	1,16				
+35	0,96	0,99	1,03	1,07	1,12	0,96	0,98	1,03	1,03	1,06	1,10				
+30	0,91	0,94	0,98	1,01	1,06	0,92	0,94	0,99	0,98	1,01	1,04				
+25	0,86	0,89	0,92	0,95	1,00	0,88	0,89	0,94	0,94	0,96	0,99				
+20	0,82	0,85	0,88	0,91	0,94	0,84	0,86	0,90	0,90	0,92	0,95				
+15	0,78	0,81	0,84	0,86	0,89	0,81	0,82	0,87	0,86	0,88	0,91				
+10	0,75	0,77	0,80	0,82	0,85	0,78	0,79	0,83	0,83	0,85	0,87				
+5		0,74	0,76	0,78	0,81		0,76	0,80	0,79	0,81	0,83				
0		0,71	0,73	0,75	0,78		0,73	0,77	0,77	0,78	0,80				
-5			0,70	0,72	0,74			0,74	0,74	0,75	0,77				
-10			0,68	0,69	0,71			0,72	0,71	0,73	0,74				
Correction Factor $K_{\Delta p}$															
Δp (bar)	0,05	0,10	0,15	0,20	0,25	0,30	0,35	0,40	0,45	0,50	0,55	0,60	0,65	0,70	0,75
$K_{\Delta p}$	1,73	1,22	1,00	0,87	0,77	0,71	0,65	0,61	0,58	0,55	0,52	0,50	0,48	0,46	0,45

2. Liquid Application

Liquid Temperature entering Valve °C	R 404A						Correction Factor K_t Evaporating Temperature °C						R 507					
	+10	0	-10	-20	-30	-40	+10	0	-10	-20	-30	-40	+10	0	-10	-20	-30	-40
+60	1,74	1,88	2,06	2,28	2,57	2,95	1,71	1,83	1,98	2,18	2,43	2,75						
+55	1,46	1,55	1,68	1,83	2,01	2,25	1,43	1,52	1,62	1,76	1,92	2,12						
+50	1,26	1,34	1,43	1,54	1,68	1,84	1,24	1,31	1,40	1,49	1,61	1,76						
+45	1,12	1,18	1,26	1,34	1,45	1,57	1,11	1,17	1,23	1,31	1,40	1,52						
+40	1,02	1,07	1,13	1,20	1,28	1,38	1,01	1,06	1,11	1,17	1,25	1,34						
+35	0,93	0,97	1,02	1,08	1,15	1,23	0,93	0,97	1,01	1,07	1,13	1,20						
+30	0,86	0,90	0,94	0,99	1,05	1,11	0,86	0,89	0,93	0,98	1,03	1,09						
+25	0,80	0,83	0,87	0,92	0,97	1,02	0,80	0,83	0,87	0,91	0,95	1,01						
+20	0,75	0,78	0,81	0,85	0,90	0,95	0,75	0,78	0,81	0,85	0,89	0,93						
+15	0,71	0,73	0,76	0,80	0,84	0,88	0,71	0,73	0,76	0,79	0,83	0,87						
+10	0,67	0,69	0,72	0,75	0,79	0,83	0,67	0,69	0,72	0,74	0,78	0,81						
+5		0,66	0,68	0,71	0,74	0,78		0,65	0,68	0,70	0,73	0,76						
0		0,63	0,65	0,68	0,71	0,74		0,62	0,64	0,66	0,69	0,72						
-5			0,62	0,65	0,67	0,70			0,61	0,63	0,65	0,68						
-10			0,60	0,62	0,64	0,67			0,58	0,60	0,62	0,64						

Liquid Temperature entering Valve °C	R 407C				Correction Factor K_t Evaporating Temperature °C													
	+10	0	-10	-20														
+60																		
+55	1,28	1,34	1,40	1,48														
+50	1,17	1,22	1,27	1,33														
+45	1,08	1,12	1,17	1,22														
+40	1,01	1,04	1,08	1,13														
+35	0,94	0,98	1,01	1,05														
+30	0,89	0,92	0,95	0,99														
+25	0,84	0,87	0,90	0,93														
+20	0,80	0,82	0,85	0,88														
+15	0,76	0,78	0,81	0,84														
+10	0,73	0,75	0,77	0,80														
+5		0,72	0,74	0,76														
0		0,69	0,71	0,73														
-5			0,68	0,70														
-10			0,65	0,67														

Correction Factor $K_{\Delta p}$															
Δp (bar)	0,05	0,10	0,15	0,20	0,25	0,30	0,35	0,40	0,45	0,50	0,55	0,60	0,65	0,70	0,75
$K_{\Delta p}$	1,73	1,22	1,00	0,87	0,77	0,71	0,65	0,61	0,58	0,55	0,52	0,50	0,48	0,46	0,45

3. Hot Gas Application

K_t	Correction Factor K_t Evaporating Temperature °C											
	+10	+5	0	-5	-10	-15	-20	-25	-30	-35	-40	
K_t	0,96	1,00	1,03	1,06	1,10	1,13	1,17	1,20	1,24	1,29	1,33	

Correction Factor $K_{\Delta p}$										
Δp (bar)	0,35	0,50	0,70	1,00	1,50	2,00	2,50	3,00	4,00	
$K_{\Delta p}$	1,72	1,49	1,22	1,00	0,86	0,78	0,73	0,70	0,65	

Dimensions 110

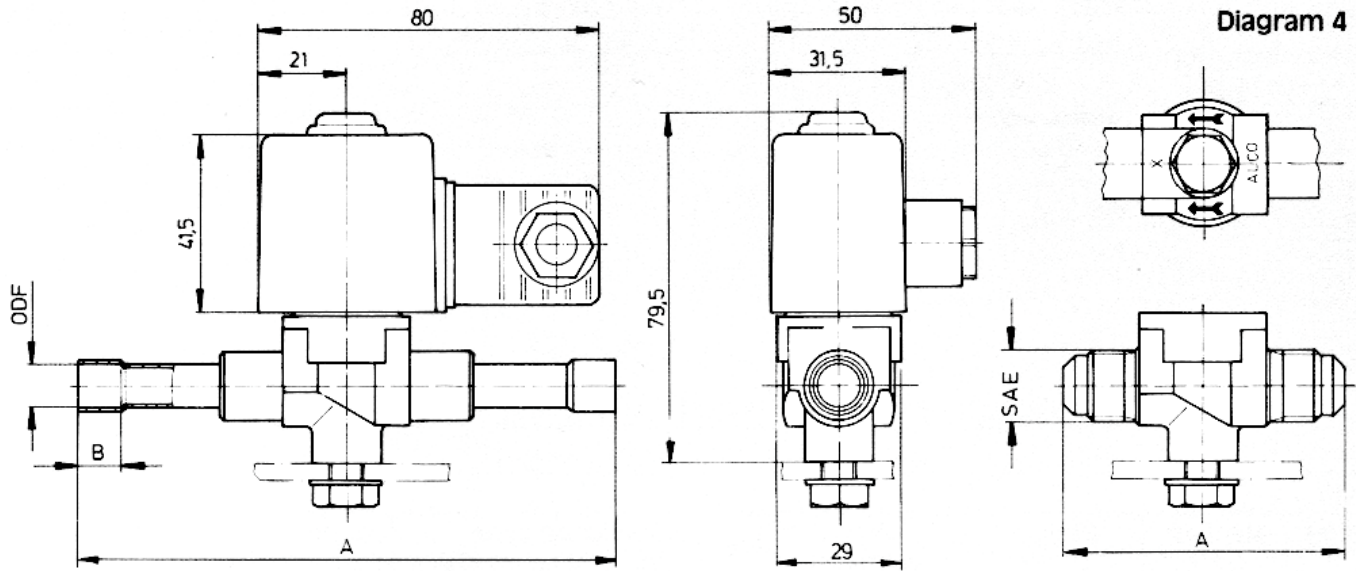

Diagram 4

Type	Ø Port	FlareODF		Solder SAE		A	B	Weight incl.coil (kg)
		mm	inch	mm	inch			
110RB 2T2	3	6	1/4			126	8	0,4
110RB 2T3	3	10	3/8			126	8	0,4
110RB 2F2	3			6	1/4	66		0,4
110RB 2F3	3			10	3/8	66		0,4

Dimensions 200

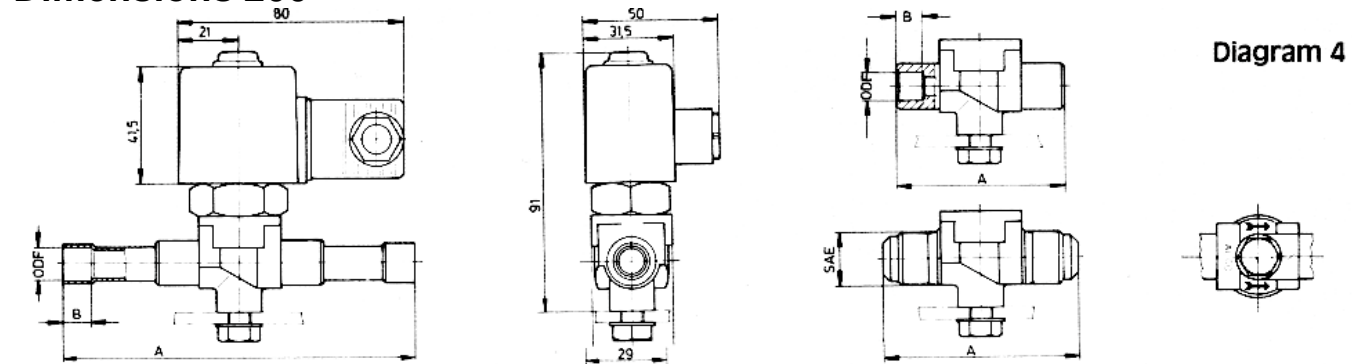
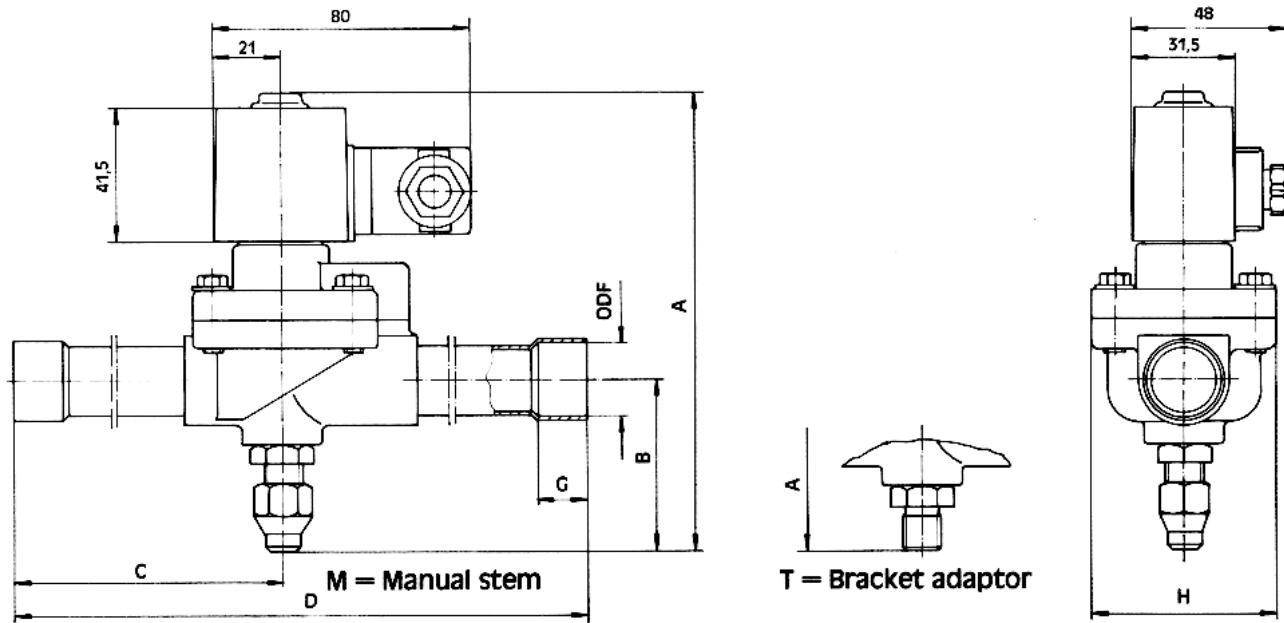

Diagram 4

Type	Ø Port	FlareODF		Solder SAE		A	B	Weight incl.coil (kg)
		mm	inch	mm	inch			
200RB 4S3	6	10	3/8			60	12	0,5
200RB 4S4	6	12	1/2			60	14	0,5
200RB 4T3	6	10	3/8			126	8	0,5
200RB 4T4	6	12	1/2			126	10	0,5
200RB 4F3	6			10	3/8	66	-	0,5
200RB 6S4	10	12	1/2			60	14	0,5
200RB 6S5	10	16	5/8			60	14	0,5
200RB 6T4	10	12	1/2			126	10	0,5
200RB 6T5	10	16	5/8			126	13	0,5
200RB 6F4	10			12	1/2	70	-	0,5
200RB 6F5	10			16	5/8	74	-	0,5

Dimensions 240 / 540



Type	Ø Port	Conn. size (mm)	A	B	C	D	G	H	Weight incl.coil (kg)
240RA 8T5-T	12,5	16	122	34	82	175	13	52	1,1
240RA 8T5-M	12,5	16	143	55	82	175	13	52	1,1
240RA 9T5-T	15	16	129	38	82	175	13		1,4
240RA 9T5-M	15	16	150	59	82	175	13		1,4
240RA 9T7-T	15	22	129	38	85	181	19	58	1,4
240RA 9T7-M	15	22	150	59	85	181	19	58	1,4
240RA 12T7-T	20	22	129	38	89	191	19	58	1,4
240RA 12T7-M	20	22	150	59	89	191	19	58	1,4
240RA 16T9-T	25	28	136	45	109	230	23	86	2,9
240RA 16T9-M	25	28	157	66	109	230	23	86	2,9
240RA 20T11-M	32	35	173	68	130	275	24	103	4,5
240RA 20T13-M		42			150	315	28		
240RA 20T17-M		54			167	349	34		